



PRILINK PRI Management System

Installation Guide

Table of Contents

1	HARDWARE INSTALLATION.....	3
1.1	CONNECTING TO ISDN-PRI NETWORKS	4
1.2	PROFILE	5
2	LAN SETUP	7
2.1	DEFAULT SETTINGS	8
3	SOFTWARE INSTALLATION.....	9
3.1	NEW INSTALLATION.....	9
3.2	SOFTWARE UPGRADES.....	9

1 Hardware Installation

A Prilink hardware unit collects and analyzes traffic data by monitoring PRI Data Channels (D-Channels) through its 8 monitor ports.

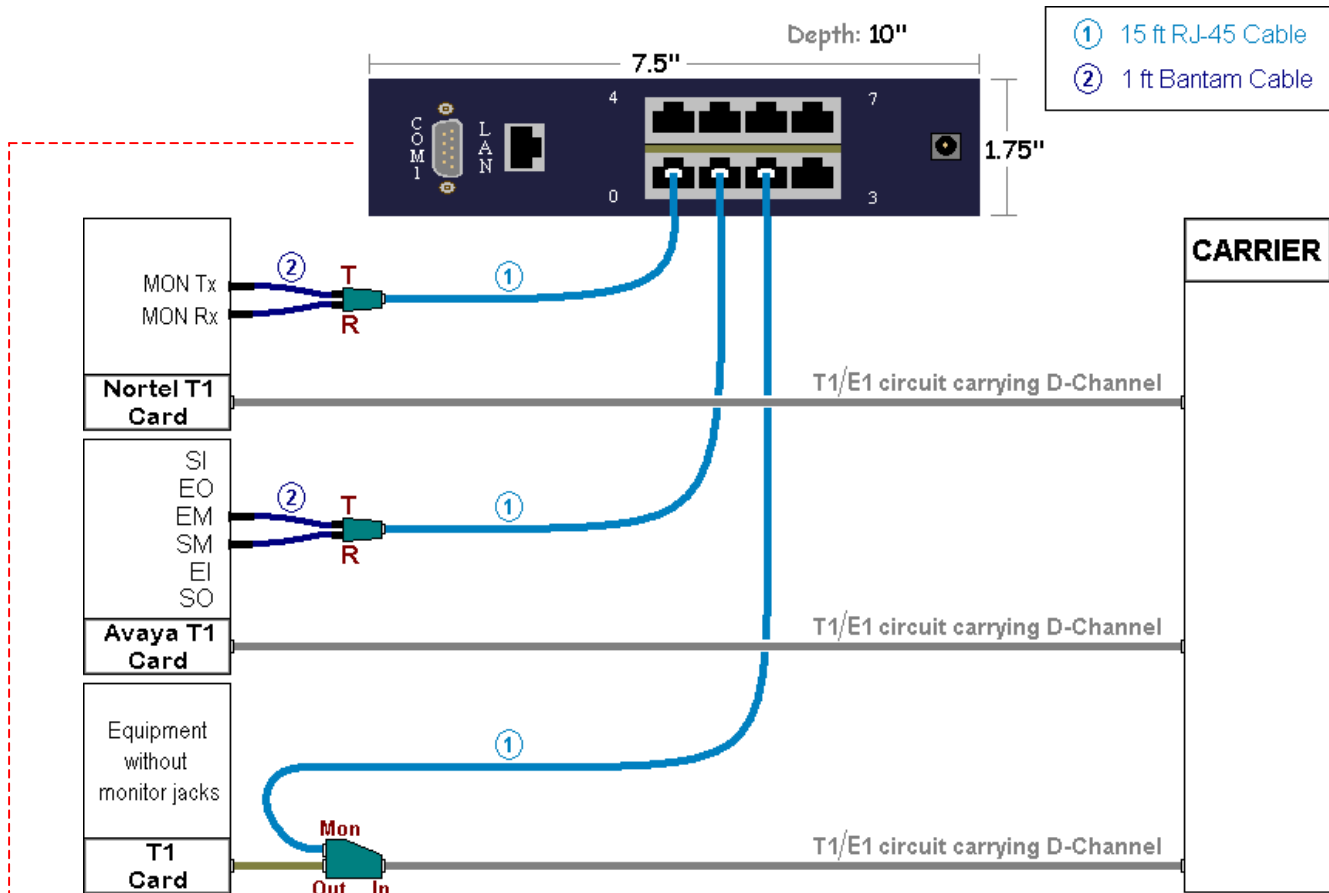

COM1: RS-232 serial port provides dial-up access to the unit through an attached external modem. The unit can also be connected directly to the COM port of a PC through null modem cable.
LAN: RJ-45 jack provides access to the unit through Ethernet LAN.

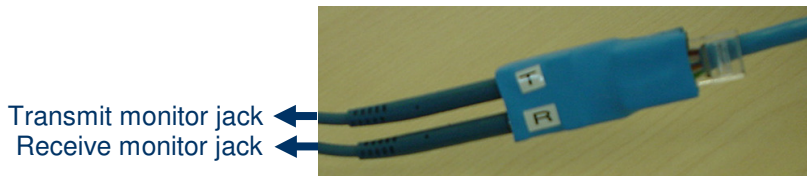

A **Bantam-RJ45 Adapter** interfaces the Prilink hardware unit to a D-channel via monitor jacks on vendor equipment.

A **T1/E1 bridge adapter** interfaces the Prilink unit to a D-channel when monitor jacks are unavailable. The T1/E1 circuit must be momentarily de-activated while the bridge is installed.

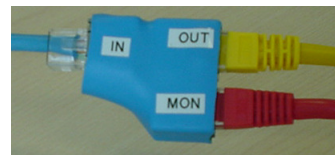

1.1 Connecting to PRI Networks

In this manual the term **PRI** is used to refer to a group of T1/E1 circuits controlled by the same D-channel. In general, a PRI may consist of a single T1/E1 controlled by a dedicated D-channel, or a group of up to 32 T1s/E1s controlled by a Primary and Secondary D-channel. Signaling on an PRI network is handled in three basic ways:

1) **Facility-associated signaling (FAS):**

Each T1/E1 is controlled by a dedicated D-Channel. Prilink must interface with each T1/E1 using FAS in order to monitor the traffic carried on it.

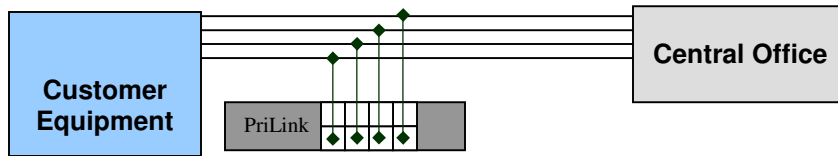

Ex. 1

4 independent T1s. Each T1 carries a D-Channel.

2) **Nonfacility-associated simplex signaling (NFAS simplex):**

A group of T1s/E1s are controlled by a single D-channel. Prilink must interface with the T1/E1 carrying the D-channel in order to monitor traffic over the whole group.

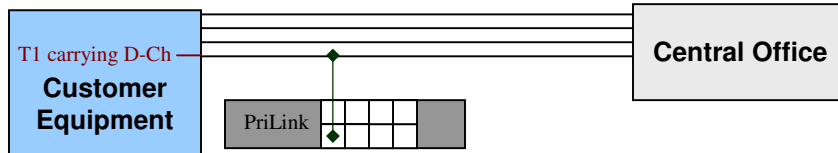

Ex. 2

4 T1s in a NFAS simplex group. Only one T1 carries a D-channel.

3) **Nonfacility-associated duplex signaling (NFAS duplex):**

Similar to NFAS simplex, except that a second T1 in the group also has a D-Channel. This is a backup D-Channel, which remains in a standby state until the active D-Channel fails, in which case the backup D-channel becomes active. The two D-Channels are termed Primary and Secondary. Prilink must interface with the active D-channel in order to monitor traffic over the whole group. Since the active D-channel may switch from Primary to Secondary, Prilink needs to interface with both to guarantee complete capture of network traffic.

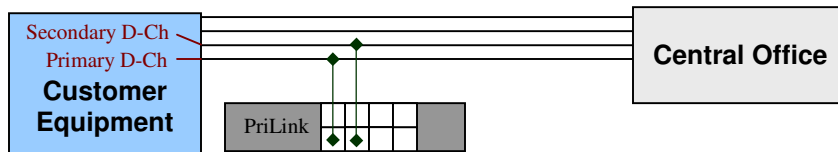

Ex. 3

4 T1s in a NFAS duplex group. Two of the T1s carry D-Channels.

Important : Failure to connect the Secondary D-channel to the Prilink base unit's monitor port will result in an inability to monitor traffic in the event of a Primary D-channel failover to the backup Secondary D-Channel.

The Primary and Secondary D-Channels are carried on two different T1/E1 lines. You must identify both before connecting the Prilink base unit.

Each base unit can connect to up to 8 independent T1/E1 lines using FAS, or 8 independent NFAS simplex groups, or 4 independent NFAS duplex groups. Combinations of FAS and NFAS groups are also possible. The figure below illustrates one such combination:

Example 4.

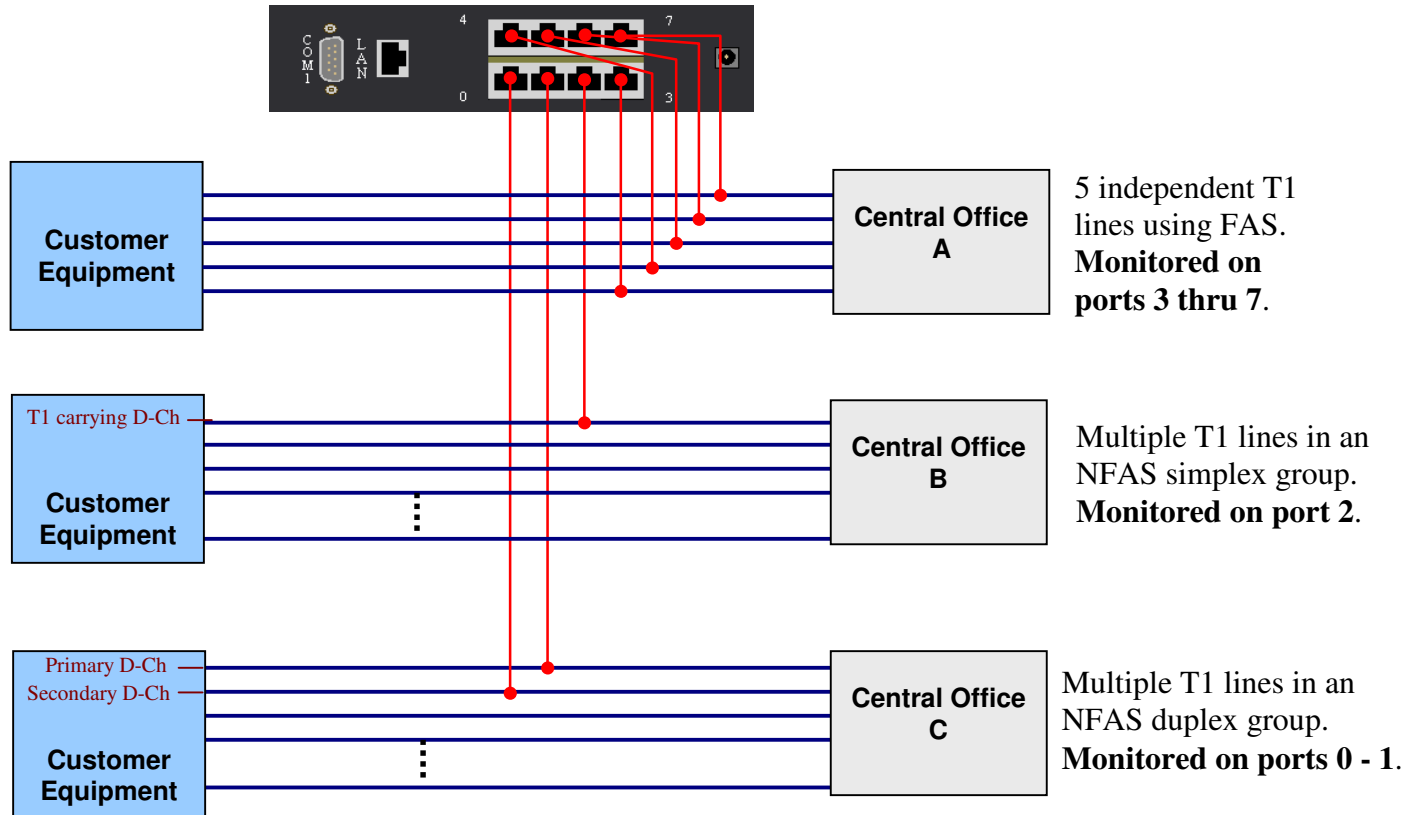

1.2 Profile

In **Example 4** above, ports 2 – 7 are monitoring independent D-Channels, while ports 0 – 1 are monitoring a Primary/Secondary D-Channel pair. In order to interpret data correctly, the Prilink unit must be aware of which ports are monitoring independent D-Channels, and which are monitoring Primary and Secondary D-Channels for the same NFAS group.

All combinations of PRI which can be connected to a single Prilink unit fall into one of five different **Profiles**. All five Profiles are listed in the table below:

Profile	Port 0	Port 1	Port 2	Port 3	Port 4	Port 5	Port 6	Port 7
1. (Example 1 and 2)	Pri	Pri	Pri	Pri	Pri	Pri	Pri	Pri
2. (Example 3 and 4)	Pri / Sec		Pri	Pri	Pri	Pri	Pri	Pri
3.	Pri / Sec		Pri / Sec		Pri	Pri	Pri	Pri
4. (Example 5)	Pri / Sec		Pri / Sec		Pri / Sec		Pri	Pri
5.	Pri / Sec		Pri / Sec		Pri / Sec		Pri / Sec	

Pri = Independent D-Channel (FAS or NFAS simplex group) or empty

Pri / Sec = Primary/Secondary D-Channel pair (NFAS duplex)

Connect the Prilink unit in accordance with one of the five Profiles listed above, and make a note of the Profile used (this will be needed when configuring the unit through the client software, see [3.1 Setting the Profile](#)).

Example 5. Three independent NFAS duplex groups

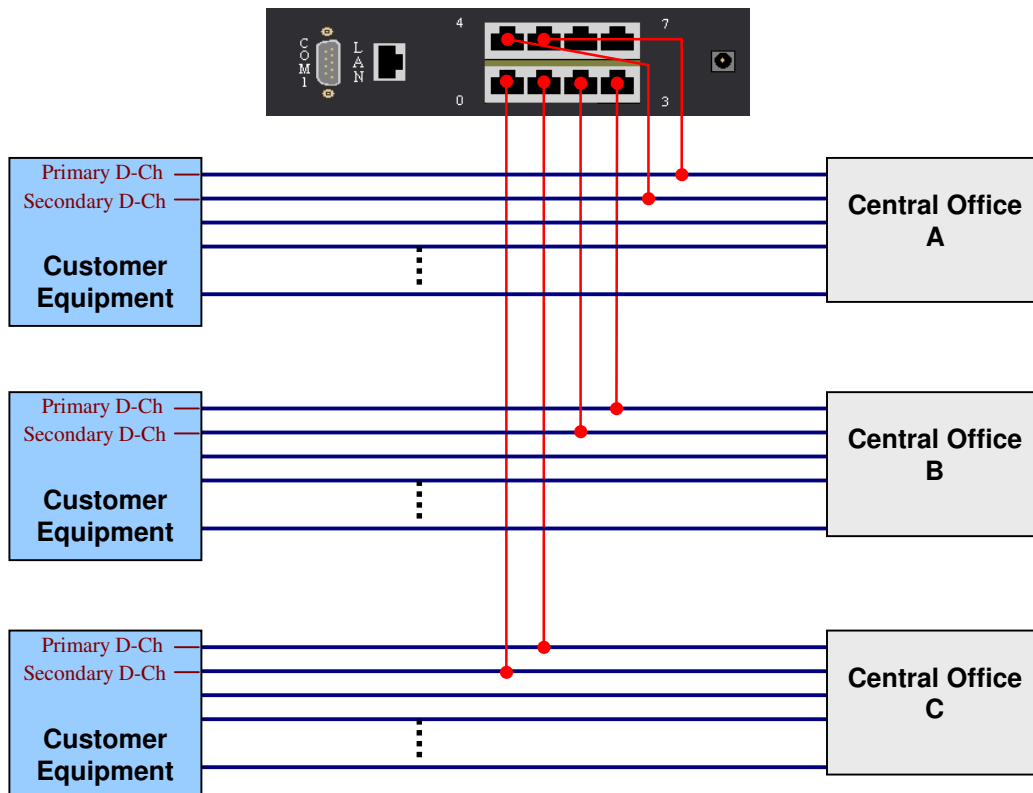

2 LAN setup

For network access, the PriLink unit must be assigned a static IP address. To assign an IP address for the first time, perform the following steps:

- 1) Identify an available static IP address that is not in use by any other device on your network.
- 2) Note the MAC Address of the PriLink unit, printed on the label directly above the LAN port (it has the form XX-XX-XX-XX-XX-XX).
- 3) Select a Windows based host from which to assign an IP address to the PriLink unit.
Note: You will not be able to assign an IP address across routers or gateways, so this host must be connected to the same subnet.

4) Open a command prompt (**Start** → **Run** → Enter “cmd” and hit **OK**).

5) Enter the following to create an entry in the host’s ARP table:

```
> arp -s xxx.xxx.xxx.xxx XX-XX-XX-XX-XX-XX
                ▲                ▲
                IP Address        MAC Address
```

6) Open a Telnet connection on port 1:

```
> telnet xxx.xxx.xxx.xxx 1
```

The connection will fail quickly, but the unit has *temporarily* assigned itself the indicated IP address.

7) Open a Telnet Connection on port 9999:

```
> telnet xxx.xxx.xxx.xxx 9999
```

Press enter within 5 seconds to go into Setup Mode.

8) Select Option 0 “Server”.

9) Enter the IP Address. *When prompted for other settings, such as Gateway and Netmask, simply hit Enter to preserve defaults.*

10) Select Option 9 “Save Settings and Exit”.

Steps 7-10 can be used at any time to change the IP address of the unit, although repeating steps 1-10 will also work (and may be required if the original IP address has been forgotten).

2.1 Default Settings

In Setup Mode (telnet 9999) there are several configurations options. Edit only option 0 “Server” to assign an IP address. All other options should be left at their default values.

1. Channel 1

Baudrate	115200
I/F Mode	4C
Flow	02
Port No	3001
ConnectMode	C0
Send '+++’ in Modem Mode	Y
Show IP after ‘RING’	Y
Auto increment source port	N
Remote IP Address	000.000.000.000
Remote Port	0
DisConnMode	00
FlushMode	22
DisConnTime	00:00
SendChar 1	00
SendChar 2	00

Ethernet connection type values:

0 = Auto-negotiation
1 = 10Mbit / half duplex
2 = 10Mbit / full duplex
3 = 100Mbit / half duplex
4 = 100Mbit / full duplex

5. Expert

TCP Keepalive time in s	45
ARP Cache timeout in s	600
CPU Performance	0
Disable Monitor Mode @ bootup	N
RS485 tx enable active level	0
HTTP Port Number	80
SMTP Port Number	25
MTU Size	1400
Enable Alternate MAC	N
Ethernet connection type	5

6. Security

Disable SNMP	Y
Disable Telnet Setup	N
Disable TFTP Firmware Update	Y
Disable Port 77FEh	Y
Disable Web Server	Y
Disable Web Setup	Y
Disable ECHO ports	Y
Enable Enhanced Password	N
Disable Port 77F0h	Y

3 Software Installation

A Prilink base unit can be accessed by users running PrilinkII Application software on a Windows based PC. In order to access the unit, the PC must have the following:

- PrilinkII application software installed
- Valid software key matching the software license number, connected to either the parallel printer port or USB port.
- One (or more) of the following:
 - Ethernet connection, with access to the IP address assigned to a base unit.
 - Modem, with dial-up access to a base unit with external modem.
 - Direct connection to a base unit via serial cable

3.1 New Installation

When installing PriLinkII software for the first time, log on to the Windows based PC **with administrator privileges**. Perform the following steps:

- 1) Insert software CD into the CD-Rom Drive.
- 2) Run **setup.exe** from the CD. Do not change the default installation directory, simply click on the icon to begin setup.
- 3) Once Setup is complete, click **Start -> Run** to bring up the *Run* pop-up window, and enter the following:

```
C:\prilinkii\hinstall.exe -i
```

Wait for "Operation successful".

- 4) Reboot PC.
- 5) Insert the software key into the parallel or USB port of the PC.

3.2 Software Upgrades

If an older version of PriLinkII software is installed on the PC, perform the following steps to install a newer version: (Users must be logged in **with administrator privileges**.)

- 1) Back up the following files (if they exist) from your `c:\prilinkii\` directory to a temporary directory:
 - i. SiteConfig.fil
 - ii. emSetup.fil (not available in some older versions)
 - iii. setup.fil
- 2) Using control panel Add/Remove programs, remove all old version of PriLinkII software.
- 3) Insert the software CD into the CD-Rom drive.
- 4) Run **setup.exe** from the CD. Do not change the default installation directory, simply click on the icon to begin setup.
- 5) Once setup is complete, click **Start -> Run** to bring up the *Run* pop-up window, and enter the following:

- i. C:\prilinkii\hinstall.exe -r
Wait for "Operation successful"
 - ii. C:\prilinkii\hinstall.exe -i
Wait for "Operation successful"
- 6) Reboot PC.
- 7) Move the files copied to a temporary directory in step 1 back into c:\prilinkii\
Overwrite the existing versions.

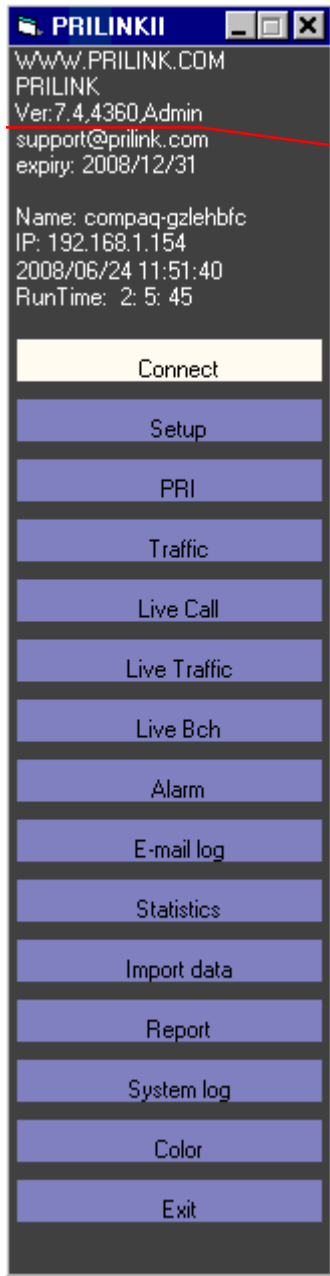

If PrilinkII software has been installed properly, the application should be accessible through **Start → Programs → PrilinkII**.

(Version and Software License Number)

The *Main Application Menu Bar* is shown on the left, which is the access point to all of PrilinkII's rich set of features. Please consult the Prilink User Manual for detailed documentation on each of these features.